



LIGHTING THAT OUTPERFORMS
SINCE 1998

LUNA 200

The Luna 200 is designed to create indirect ambient lighting. Its unique surface allows the fixture to blend discretely, or make a noticeable statement in its environment with its elegant aesthetics and captivating backlight. Available in three finishes and three colour selectable.

PRODUCT SPECIFICATIONS

Installation	Fixed Surface Mount
Finish	Black/Satin Brass/White
Material	Aluminum
Beam Angle	120°
Wattage	7W
Voltage	240V 50Hz
Power Factor	0.95
Dimming	Trailing Edge/Universal
LED	SMD
Colour Temp	3000K, 4000K, 6000K
CRI	>90
Lumen	170lm (3K), 190lm (4K), 180lm (6K)
Lamp Expectancy	>40,000hrs
IP Rating	IP20
Warranty	3 Years

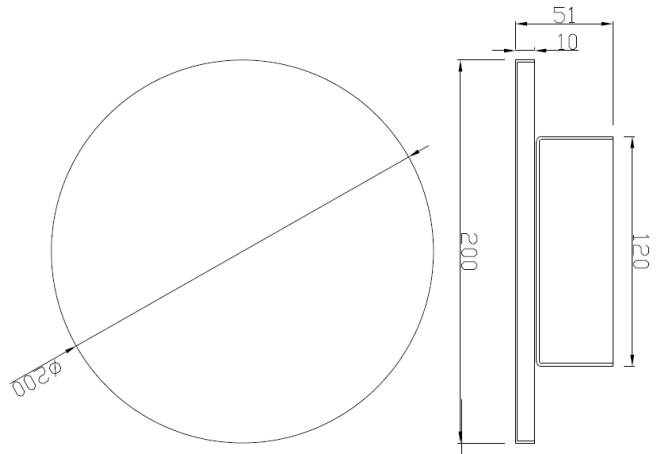

ORDERING CODES



UGE ACCESSORIES

DESCRIPTION	MODEL NUMBER	IMAGE
LED Push Button Dimmer	UDIMMER-350	